

FOR GENERAL REFERENCE ONLY
Models shown may not match the model features or manuf year of the item offered by AERE.



MPM-48

MPM SERIES

Medium Temp Open Display Merchandisers

MODELS

- MPM-36
- MPM-48
- MPM-72

FEATURES

STANDARD TEXTURED FINISH



Standard white

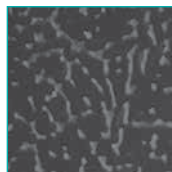

Black also available

CONSTRUCTION

- 24 gauge painted textured steel interior and exterior
- Removable two tier stainless steel display deck
- Stainless steel floor
- Full length 8³/₄" wide laminated white formica counter top
- Front bumper guard
- Automatic defrost
- On/off power switch on MPM-36 and MPM-48

- Cord and plug on MPM-36 and MPM-48
- Black vinyl trim
- 2" foamed-in-place "zero ODP" urethane insulation

REFRIGERATION

- Refrigerant: R-134a
- Front air intake and rear discharge
- Forced air ducted flow
- Self-contained, bottom mount refrigeration system
- Minimum of 6" clearance between cabinet back and wall and a clearance of 10" at top
- Temperature range: 34° to 41°F (1° to 5°C)
- R-factor (insulation efficiency rating): 17.24
- Slide-out refrigeration system
- **Drain plumbing hookup recommended. Condensate pan available if there is no access to drain plumbing. Condensate pan must be field installed and requires a dedicated 15 amp, 120 volt circuit.**

WARRANTY

- Standard limited two year parts and labor
- Additional three year coverage on compressor part

OPTIONS

- Add suffix "SS" for stainless steel interior and exterior
- Custom colors
- Night curtain kit (factory installed)
- Light kit (factory installed)
- Night curtain & light kit (factory installed)
- Casters
- Sandwich racks
- Sandwich rack dividers
- Condensate evaporator drain pan
NOTE: Must be field installed and requires a dedicated 20A, 120v circuit.



MPM SERIES

MEDIUM TEMP OPEN DISPLAY MERCHANDISERS

TECHNICAL SPECIFICATIONS

MODEL	DIMENSIONS (in.)			DIMENSIONS (mm)			VOLTS	AMPS	UNIT H.P.	CAP. CU. FT.	SHIP CU. FT.	SHIP WT. LB/KG
	L	D	H	L	D	H						
MPM-36	36	30 1/2	43 1/4	914	787	1099	115	10.3	1/3	3.7	41.0	310/141
MPM-48	48	30 1/2	43 1/4	1219	787	1099	115	15.5	1/2	5.1	53.0	410/220
MPM-72	72	30 1/2	43 1/4	1829	787	1099	115	15.8	3/4	7.9	86.0	590/268

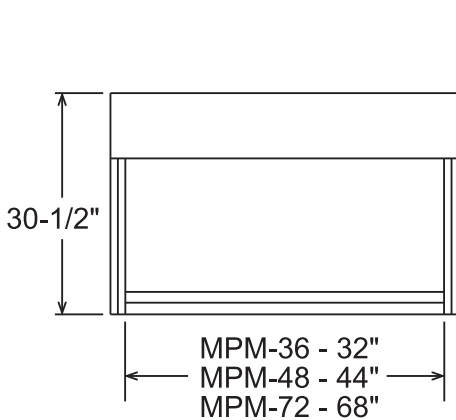

PLAN VIEW

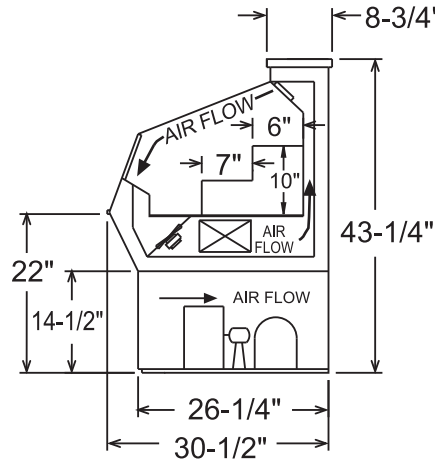

SIDE VIEW

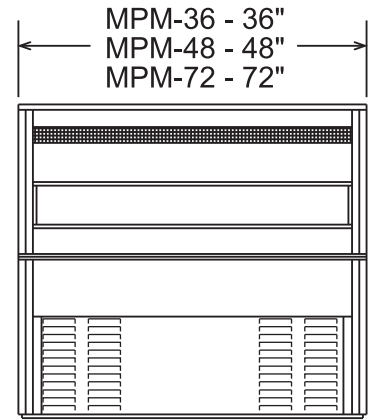

ELEVATION VIEW

LISTINGS



ANSI/NSF 7

HOOKUP

MPM-36 and MPM-48 via plug-in, 9 foot long, flexible three wire 14/3 cord with molded plug. MPM-72 model hardwired.

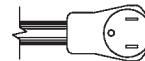

NEMA 5-15P (MPM-36)

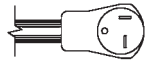

NEMA 5-20P (MPM-48)

RECOMMENDED OPERATING CONDITIONS

- Merchandisers designed to hold product in the 34° to 41°F (1° to 5°C) range
- Designed to operate in air-conditioned stores where the maximum temperature is 75°F and the maximum relative humidity is 55%

- Should not be installed in direct sunlight
- Should not be installed near HVAC vents, fans or doorways that will disrupt airflow and compromise the function of the air screen inside the case
- Bottom shelf should not be loaded such

- that the front air intake is obstructed
- Factory installed controls should not be altered, removed or replaced without consent of the factory
- Product must not be displayed in the cold air curtain

BID SPECIFICATIONS

Item no. MPM-_____
Provide _____ () Medium Temp Open Display Merchandiser(s), Master-Bilt model no. MPM-_____.

Merchandiser to be constructed of 24 gauge painted textured galvanized steel interior and exterior with removable two tier

stainless steel display deck and stainless steel floor. Other standard features include full length 8 3/4" wide laminated white formica counter top, front bumper guard, automatic defrost, on/off power switch (MPM-36 and MPM-48 only), black vinyl trim and have foamed-in-place "zero ODP"

urethane insulation. The temperature range of the merchandiser will be 34° to 41°F (1° to 5°C). Merchandiser to have standard limited two year parts and labor with additional three year coverage on compressor part.

Merchandiser to be UL and C-UL listed and UL EPH classified.

NOTE: All specifications subject to change without notice.



908 Highway 15 North • New Albany, MS 38652

PHONE: 800-647-1284 or 662-534-9061 • FAX: 800-232-3966 or 662-534-6049 • www.master-bilt.com

