

Indigo™ Series 1106 Ice Cube Machine

Model: ID-1106A IY-1106A ID-1106W IY-1106W ID-1196N IY-1196N



Indigo Series i-1106
Ice Machine on B-570 Bin

Designed for operators who know that ice is critical to their business, the Indigo™ Series ice machine's preventative diagnostics continually monitor itself for reliable ice production. Improvements in cleanability and programmability make your ice machine easy to own and less expensive to operate.

- **New Levels of Performance** – showcasing reductions in energy consumption and improved ambient ice production: up to 9% reduction in energy and up to 20% improvement in ice production.
- **EasyRead Display** – communicates operating status, cleaning reminders, and asset information through a blue illuminated display.
- **Programmable Ice Production** – by On/Off Time, Ice Volume or Bin Level (with accessory bin level control) further improves energy efficiency and savings.
- **Easy to Clean Foodzone** – Hinged front door swings out for easy access. Removable water-trough, distribution tube, curtain, and sensing probes for fast and efficient cleaning. Select components made with AlphaSan® antimicrobial.
- **Intelligent Diagnostics** – provide 24 hour preventative maintenance and diagnostic feedback for trouble free operation.
- **Acoustical Ice Sensing Probe** – for reliable operation in challenging water conditions.
- **DuraTech™ Exterior** – provides superior corrosion resistance. Stainless finish with innovative clear-coat resists fingerprints and dirt.
- Available **LuminIce™ Growth Inhibitor** controls the growth of bacteria and yeast within the foodzone.

Ice Machine Electric

208-230/60/1 standard
(208-230/60/3 and 230/50/1 also available.)

Minimum circuit ampacity:

Air-cooled:	13 1ph	9.8 3ph
Water-cooled:	11.9 1ph	8.7 3ph
Remote:	12.9 1ph	9.7 3ph

Maximum fuse size:

Air-cooled:	20 1ph	15 3ph
Water-cooled:	20 1ph	15 3ph
Remote:	20 1ph	15 3ph

Specifications

BTU Per Hour:

16,250 (average) 18,600 (peak)

Refrigerant:

R-404A CFC-free

Operating Limits:

- Ambient Temperature Range: 35° to 110°F (1.7° to 43.3°C)
Water Temperature Range: 35° to 90°F (1.7° to 32.2°C)
- Water Pressure Ice Maker Water In:
Min. 20 psi (137.9 kPa)
Max. 80 psi (551.1 kPa)



Ice Shape



Half Dice
3/8" x 1 1/8" x 7/8"
(.95 x 2.86 x 2.22 cm)



Dice
7/8" x 7/8" x 7/8"
(2.22 x 2.22 x 2.22 cm)



COMPANY WITH
QUALITY SYSTEM



Indigo™ Series 1106 Ice Cube Machine

i-1106 on B-570 Storage Bin

- (A) Electrical Entrance (2) Options
- (B) 3/8" (0.95 cm) F.P.T. Water Condenser Inlet (water-cooled units)
- (C) 1/2" (1.27 cm) F.P.T. Water Condenser Outlet (water-cooled units)
- (E) 3/8" (0.95 cm) F.P.T. Ice Making Water Inlet
- (F) 1/2" (1.27 cm) F.P.T. Ice Making Water Drain
- (G) 3/4" (1.91 cm) Bin Drain

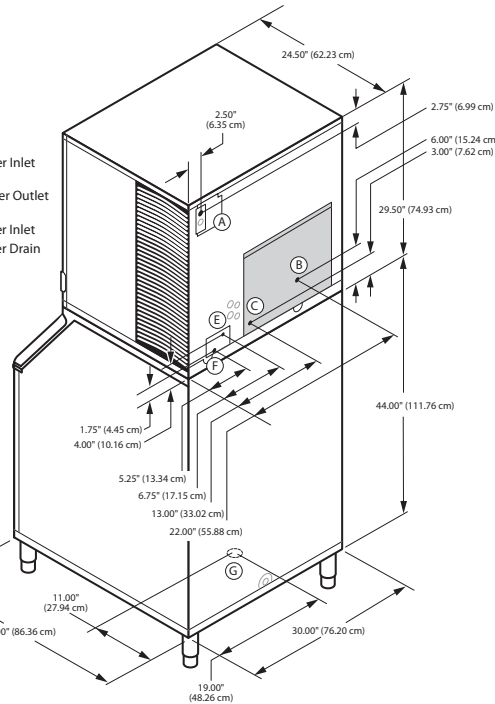

Installation Note
Minimum installation clearance:
Top/sides: 8" (20.32 cm);
Back is 5" (12.7 cm)

Space-Saving Designs



	i-1106 B-570	i-1106 B-970*
Height	79.50"	79.50"
	201.93 cm	201.93 cm
Width	30.00"	48.00"
	76.20 cm	121.92 cm
Depth	34.00"	34.00"
	86.30 cm	86.30 cm
Bin Storage	430 lbs. 195 kgs.	710 lbs. 322.2 kgs.

Height includes adjustable bin legs 6.00" to 8.00" (15.24 to 20.32 cm) set at 6.00" (15.24 cm).

*K-00370 bin adapter required.

Specifications

	Model	Ice Shape	Ice Production 24 Hours		Power Usage kWh/100 lbs. @90°Air/70°F		Water Usage/ 100 lbs. 45.4 kgs. of Ice	ENERGY STAR*
			70°Air/ 50°F Water	90°Air/ 70°F Water	1 Ph	3 Ph	Potable Water	
AIR-COOLED	ID-1106A	dice	1,141 lbs.	846 lbs.	5.06	5.06	19.8 Gal.	★
			518 kgs.	384 kgs.			75.0 L	
	IY-1106A	half-dice	1,200 lbs.	870 lbs.	5.01	5.01	19.8 Gal.	★
			544 kgs.	395 kgs.			75.0 L	
WATER-COOLED	ID-1106W	dice	1,057 lbs.	906 lbs.	4.08	4.08	19.8 Gal.	NA
			479 kgs.	411 kgs.			75.0 L	
	IY-1106W	half-dice	1,134 lbs.	965 lbs.	3.90	3.90	19.8 Gal.	NA
			514 kgs.	438 kgs.			75.0 L	
* Water-cooled Condenser Water Usage / 100 lbs. /45.4 kgs. Of Ice: 180 gal/681 L.								
* Water-cooled models are excluded from ENERGY STAR qualification.								
REMOTE-COOLED	ID-1196N	dice	1,027 lbs.	867 lbs.	4.98	4.98	19.8 Gal.	★
			466 kgs.	393 kgs.			75.0 L	
	IY-1196N	half-dice	1,066 lbs.	922 lbs.	4.88	4.88	19.8 Gal.	★
			484 kgs.	418 kgs.			75.0 L	

Order ice storage bin separately. Ice storage bin and JC-0995 remote condenser must be ordered separately. Consult remote condenser specification sheet for details. To order 3 phase add "3" suffix to model # (ID-1002A3).

Accessories

LuminIce™ Growth Inhibitor
reduces yeast and bacteria growth for a cleaner ice machine.



Bin Level Control
Allows ice bin level to be automatically set. Built-in LED light illuminates bin.



Arctic Pure® Water Filters
Reduces sediment and chlorine odors for better tasting ice.



AuCS®
schedules and performs routine ice machine cleaning automatically.

