



FOR GENERAL REFERENCE ONLY  
Models shown may not match the  
model features or manuf year of the  
item offered by AERE.

1.06, 1.10, 2.10

## COMBI-OVENS



1.06



1.10

Extendable  
hose stores on  
the right side of  
all combi-ovens  
for convenient  
cleaning



2.10

More than 195 programmable  
processes allow for flexible  
and diverse menu options

BKI's Combi-Ovens feature an integrated system of circulating hot air and injected steam, driven by a super-powered fan motor to ensure optimal cooking conditions across a broad spectrum. The result: perfectly prepared foods, ranging from beef and fish, to vegetables and rice and even baked goods. With memory storage of more than 195 programmable processes, BKI's combi-ovens can steam, bake, reheat and proof products within a single equipment 'footprint.'

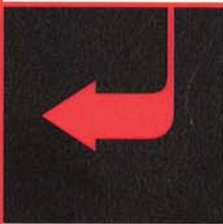

1.06

TOP VIEW

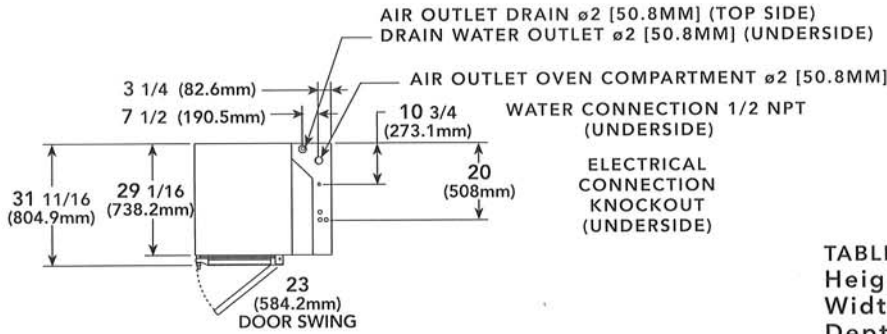

FRONT VIEW

SIDE VIEW

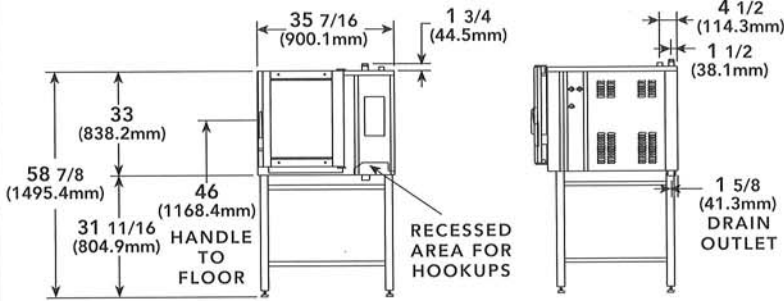

ELECTRICAL SPECIFICATIONS

Voltage	208
Phase	3
Wires	3
Amps	22
Breaker	30
kW	9.0

DIMENSIONS

TABLE MODEL

Height	33" (838.2 mm)
Width	35 7/16" (900.1 mm)
Depth	31 11/16" (804.9 mm)
Floor Space	7.8 sq.ft (.73 m <sup>2</sup> )
Shipping Weight	285 lb. (129.2 kg)
Shipping Cube	42.2 cu.ft (1.2 m <sup>3</sup> )

STAND MODEL

Height	58 7/8" (1495.4 mm)
--------	---------------------

PAN CAPACITY:

Steam Table Pan	
(6) full-size	2.50" (6cm)
Bun Pan	
(6) half-size	13" (33cm) x 18" (46cm)

1.10

TOP VIEW

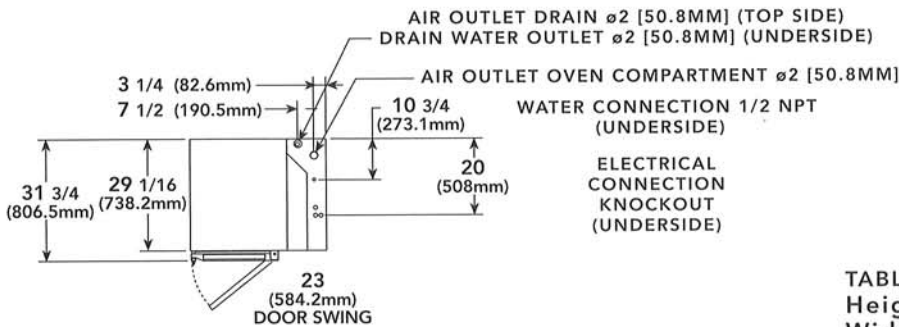

FRONT VIEW

SIDE VIEW

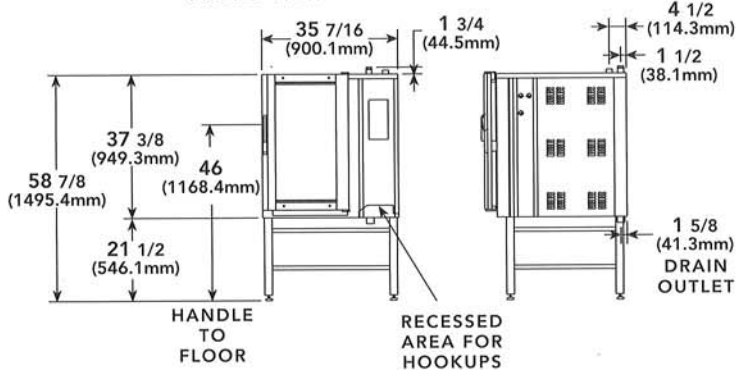

ELECTRICAL SPECIFICATIONS

Voltage	208
Phase	3
Wires	3
Amps	42
Breaker	60
kW	15

DIMENSIONS

TABLE MODEL

Height	37 3/8" (949.3 mm)
Width	35 7/16" (900.1 mm)
Depth	31 3/4" (806.5 mm)
Floor Space	7.8 sq.ft (.73 m <sup>2</sup> )
Shipping Weight	350 lb. (158.8 kg)
Shipping Cube	52.2 cu.ft (1.5 m <sup>3</sup> )

STAND MODEL

Height	58 7/8" (1495.4 mm)
--------	---------------------

PAN CAPACITY:

Steam Table Pan	
(10) full-size	2.50" (6cm)
Bun Pan	
(10) half-size	13" (33cm) x 18" (46cm)



BKI Worldwide Headquarters

P.O. Box 80400 Simpsonville, SC 29680-0400 USA • Tel: 864-963-3471 • Toll Free: 1-800-927-6887  
 Customer Service Fax: 801-459-0899 • Sales Fax: 509-352-5350

BKI Europe (U.K.)

Tel: (44) 8950 8222  
 Fax: (44) 8956 0233

BKI Latin America

Tel: 954-442-0480  
 Fax: 954-442-0480



2.10

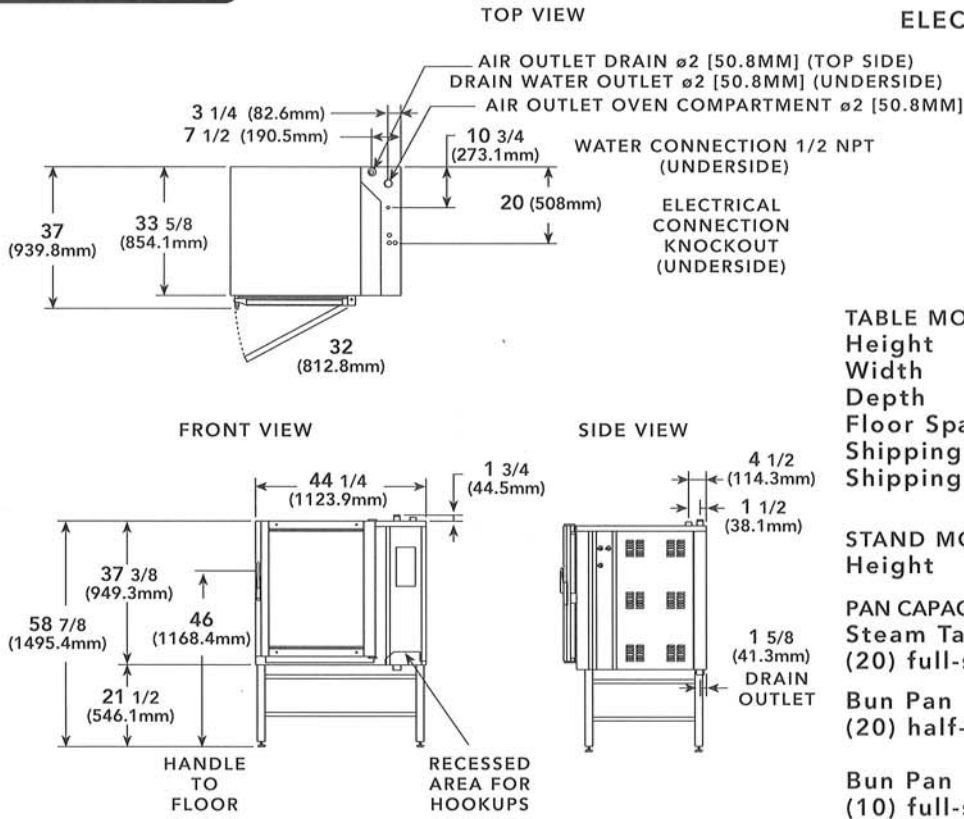

ELECTRICAL SPECIFICATIONS

Voltage	208
Phase	3
Wires	3
Amps	70
Breaker	90
kW	25

DIMENSIONS

TABLE MODEL

Height	37 3/8" (949.3 mm)
Width	44 1/4" (1123.9 mm)
Depth	37 (939.8 mm)
Floor Space	11.4 sq.ft (1.1 m <sup>2</sup> )
Shipping Weight	455 lb. (206.4 kg)
Shipping Cube	52.2 cu.ft (1.5 m <sup>3</sup> )

STAND MODEL

Height	58 7/8" (1495.4 mm)
--------	---------------------

PAN CAPACITY:

Steam Table Pan	(20) full-size 2.50" (6cm)
Bun Pan	(20) half-size 13" (33cm) x 18" (46cm)
Bun Pan	(10) full-size 18" (46cm) x 26" (66cm)

COMBI-OVEN FEATURES

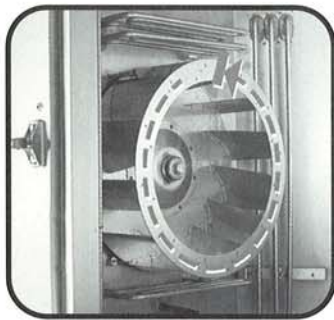

**Automatic Motor Brake**  
BKI takes extra measures to ensure operator safety with an automatic motor brake that is activated to stop the fan when the oven door is opened during operation.

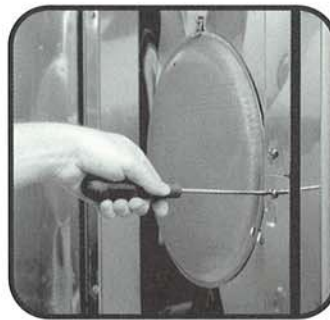

**Efficient Filter**  
An easy-to-remove filter efficiently catches fat particles during the cooking operation for superior baking results. Made of stainless steel and located in the ovens' filter housing system, the filter is dishwasher safe.



**Hand Shower**  
Integrated hand shower ensures quick and easy cleaning with a flexible and extendable hose. Stored on the outside of the oven, the flexible hose is conveniently located for simple cleaning.



BKI Worldwide Headquarters

P.O. Box 80400 Simpsonville, SC 29680-0400 USA • Tel: 864-963-3471 • Toll Free: 1-800-927-6887  
Customer Service Fax: 801-459-0899 • Sales Fax: 509-352-5350

BKI Europe (U.K.)  
Tel: (44) 8950 8222  
Fax: (44) 8956 0233

BKI Latin America  
Tel: 954-442-0480  
Fax: 954-442-0480



SANITATION

Specifications subject to change without notice.  
© BKI LI0077/4-01



1.06, 1.10, 2.10



## COMBI-OVEN FEATURES

### Safety Handle

BKI is serious about employee safety. With a two-step safety handle, the risk of scalding is reduced when oven door is opened.



### Temperature Probe

The core temperature probe yields consistent readings for proper cooking results. To prevent unnecessary heat from damaging the temperature probe, the probe is stored on the outside of the oven for accurate performance.

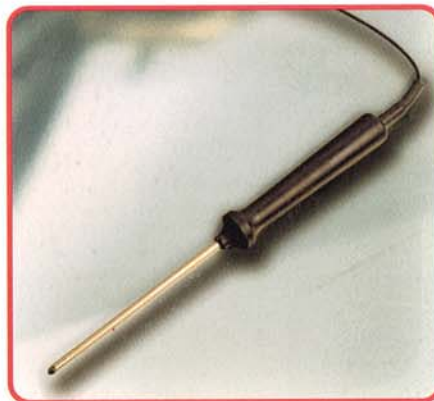

### Easy Cleaning

BKI manufactures equipment with a keen attention to detail such as rounded corners in the oven compartment for quick and efficient cleaning. With a polished stainless steel design, operators get the quality they come to expect from BKI.



### BKI Worldwide Headquarters

P.O. Box 80400 Simpsonville, SC 29680-0400 USA • Tel: 864-963-3471 • Toll Free: 1-800-927-6887  
Customer Service Fax: 801-459-0899 • Sales Fax: 509-352-5350

### BKI Europe (U.K.)

Tel: (44) 8950 8222

Fax: (44) 8956 0233

### BKI Latin America

Tel: 954-442-0480

Fax: 954-442-0480

