



ELECTRIC FRYERS (Floor Model)

Models: 618L • 624

Belshaw's 600-series electric heated open kettle fryers are designed to produce high quality donuts with low operating costs.

The heavy duty elements used by the 600 series are robust enough to withstand daily use for the entire life of the fryer. Space under the elements is reserved as a cool zone to avoid further heating of frying debris. The elements themselves tilt up to vertical to allow quicker cleaning after each shift. The kettle can be quickly removed for periodic cleaning outside the fryer.

Easy-to-use submerger screens can be added to further improve production efficiency. And Belshaw's 600-series open kettle fryers also accommodate the EZ Melt under-kettle shortening melter/filter. The EZ Melt can melt a block of shortening, and pump new shortening directly to the fryer at the touch of a foot pedal.

600 series fryers are fully compatible with Belshaw Type 'B' and Type 'F' donut depositors. Belshaw provides a full line of complementary equipment that saves labor cost and improves quality consistency:

- EP18-24 Proofing Cabinet
- Type 'B' and Type 'F' cake donut depositors
- EZ Melt Shortening Melter-Filter
- SF Shortening Filter
- HI24 Production Icers
- H&I 2-4 Icing Tables
- HG, HGEZ Hand Glazers

Products made commercially using floor model electric fryers:

- | | |
|--------------------|---------------------------------|
| ▪ Donuts | ▪ Beignets |
| ▪ Hushpuppies | ▪ Fritters, fried dough |
| ▪ Funnel cakes | ▪ Crab cakes, clam strips |
| ▪ Elephant ears | ▪ Fried corn |
| ▪ Fried pies | ▪ Fried vegetables |
| ▪ Loukoumathes | + More fried goods of all kinds |
| ▪ Falafel | |
| ▪ Paczkis, porogis | |

FOR GENERAL REFERENCE ONLY
Models shown may not match the model features or manuf year of the item offered by AERE.



Belshaw 624 Electric Fryer (with Type 'B' donut depositor and optional submerger)



618L electric fryer (18" x 26")



624 electric fryer (24" x 24")



Frying screen (identical to proofing screen, but has bolt-on handles). Screens are reinforced wire mesh, spaced 1/4" (6mm) apart, manufactured from nickel-plated steel.



Screen cradle and proofing screen. The best way to transfer raised donuts from proofer to fryer.



Detachable handles and proofing screen. For cake or raised donuts.

Standard Features

- Stainless steel tank, cabinet, and drain tray (specify whether drain tray should be on left or right side when ordering)
- Heavy duty elements, tiltable upwards for easy kettle cleanup
- 2 nickel plated cake donut frying screens with bolt-on heat dissipating handles
- Adjustable, bolt down legs
- Exterior drain valve control

Options

- Extra frying/proofing screens (fixed or detachable handles optional)
- Screen cradle - (enables easy screen usage without any need for handles)
- Submerger

600 Series Fryers - Capacity Chart

(Dozen donuts/hour @ 90-second frying time. Production will vary depending on product size, shortening temperature and composition of donut)

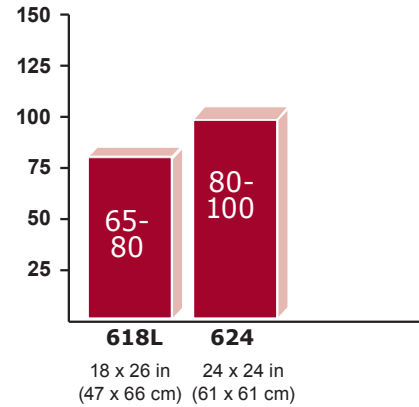

618L/624/634 Fryers

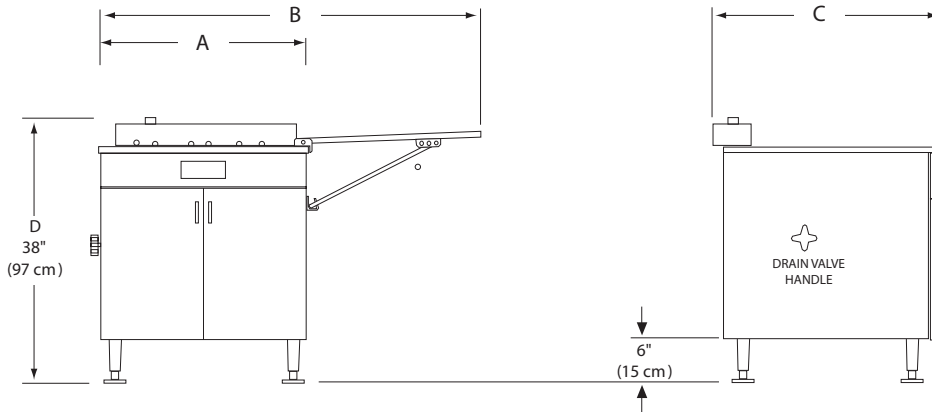

Dimensions

MODEL	A	B	C	D	FRYING AREA	SHORTENING CAPACITY	APPROX. SHIPPING WEIGHT
	Width closed	Width open	Depth	Height	Width x Depth		
618L	28" (71cm)	48" (122cm)	37" (94cm)	38" (97cm)	18" x 26" (46cm x 66cm)	83lbs (38kg)	240 lbs (110 kg)
624	34" (86cm)	59" (150cm)	35" (89cm)	38" (97cm)	24" x 24" (61cm x 61cm)	97lbs (44kg)	260 lbs (118 kg)

Energy Requirements

MODEL	208/240V 50/60hz 1ph		208/240V 50/60hz 3ph		380/415V 50/60hz 3ph	
	kW	A	kW	A	kW	A
618L	9.3/12.4	44.6/51.5	9.3/12.4	44.6/51.5	19	27
624	13.9/17.0	67/71.3	13.9/17.0	38.6/41.1	11.5	26

Screen Size And Weight

MODEL	SCREEN SIZE	APPROX. SHIPPING WEIGHT (Box of 12)
618L	17" x 25" (43 x 63 cm)	45 lbs (21 kg)
624	23" x 23" (58 x 58 cm)	55 lbs (25 kg)